

Squirrel Beaver Tail / Flat Top Trailer

The Trailer is designed for the safe loading, unloading and transport of Squirrels and other goods.
Rated ATM 3.5 tonne with a max load 2.3 tonne, available in three size drawbars.

- 8mm thick expanded floor mesh on steel floor & both sides of ramp.
- 50x25 RHS cross member every 280mm under 8mm thick expanded floor mesh tray floor, Rope rail Ø27mm on front & both sides
- Bottom prop on loading ramp.
- Ramps can fold right over to give flat top
- Different drawbar (short, medium & long) can be changed on ordering
- Head rail 0.92m high from tray, can be removed if not required
- Gap in head rail for Squirrel boom recess
- Axles Ø65mm, hubs, springs, electric brakes, wheels all rated to 4 tonne
- Electric breakaway brakes with auto charging battery back up.
- Landcruiser PCD on 15" rims
- Safety - Squirrel cage access platform, hand rail & steps bolted on, can be removed later.
- Supplied with 1 new spare wheel
- Gas struts & springs on rear ramps so lifting is no more than 9 kg
- Hand grip for easy lifting of ramps
- Foot step rail on both sides of tray
- Aluminium tool box with gas struts on lid
- LED lights with round 7 pin plug
- All frame is hot dip galvanized
- High quality trailer jockey wheel with wind up stand, load rated to 400 kg



558 or 536 Squirrel on a Trailer flat top with a short drawbar.

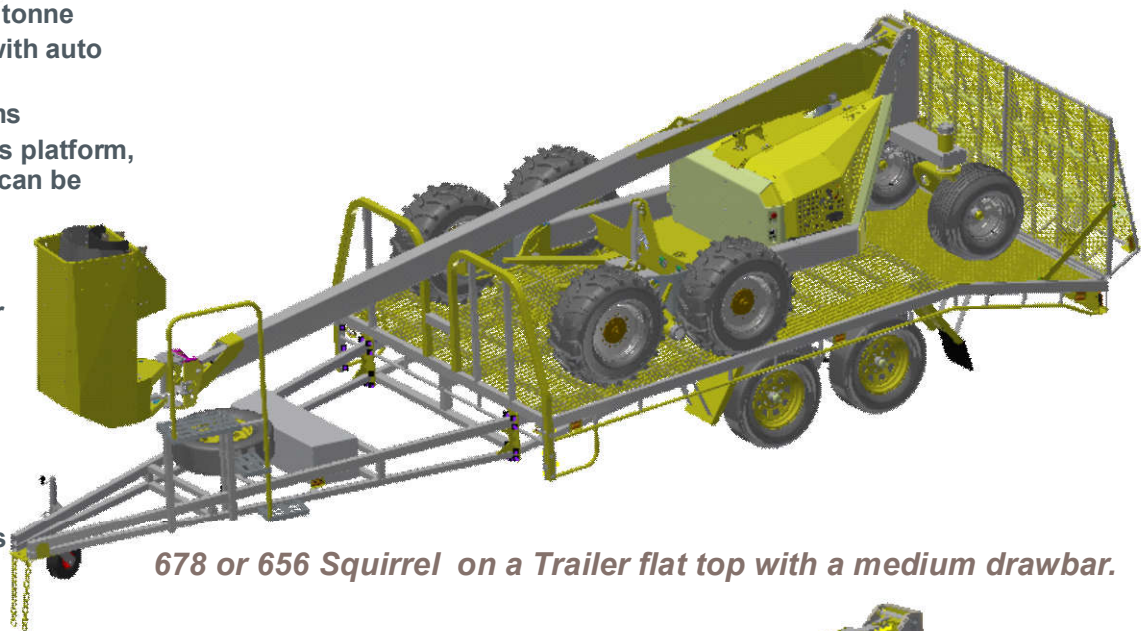

678 or 656 Squirrel on a Trailer flat top with a medium drawbar.



818 or 806 Squirrel on a Trailer flat top with a long drawbar.

Manufacturers and designers of horticultural equipment

Toll free : 1300 761 922

Phone: (08) 9731 1502

www.crendon.com.au



Available Through Your Local Dealer

Squirrel Beaver Tail / Flat Top Trailer

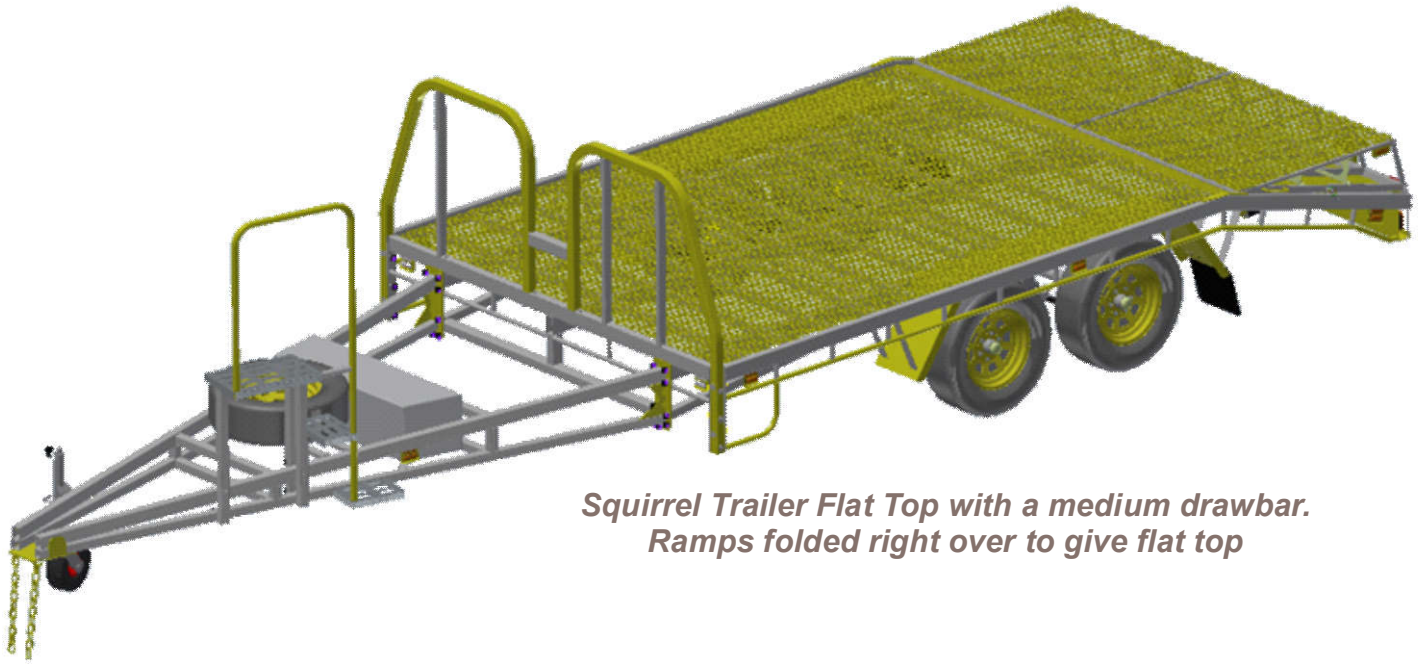

*Squirrel Trailer Flat Top with a medium drawbar.
Ramps folded right over to give flat top*

Flat Top Squirrel Trailer Specifications

| | |
|--|--|
| Trailer A.T.M | 3500 kg |
| Trailer Carrying capacity | 2300 kg |
| Tare mass | 1200 kg |
| Flat Top Tray space measurements | 4.47m long x 2.48 wide |
| Tray height | 0.79m |
| Ramp angle and length | 15° / 1.2m long |
| Total length rear of ramp in upright position | 7.1m for short drawbar 8.4m for medium drawbar 9.8m for long drawbar |
| Axles | 2 x solid Ø65mm, Inner and outer bearing min 2 x 68149, (rated at 4.5 tonne) |
| Springs | 8 leaf tandem rock/roll 60mm X 6.5mm (rated at 4 tonne). |
| Brakes | electric drum 12" x 2.5" with manual park brake |
| Tyres | 195R15C, 8 ply, load rating 950 kg |
| Rim | Land Cruiser 15 x 6", 6 stud pattern |
| Wiring | LED, 12V 7 pin small metal round plug |
| Finish | Hot Dip galvanised & silver paint |
| Tool box size | 1100mm(L) x 320mm(W) x 300mm(H) |

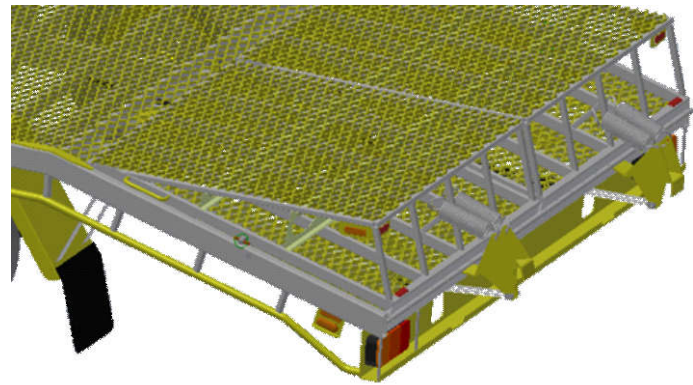

Ramps folded right over to give flat top. Four tension springs make this easy to swing over

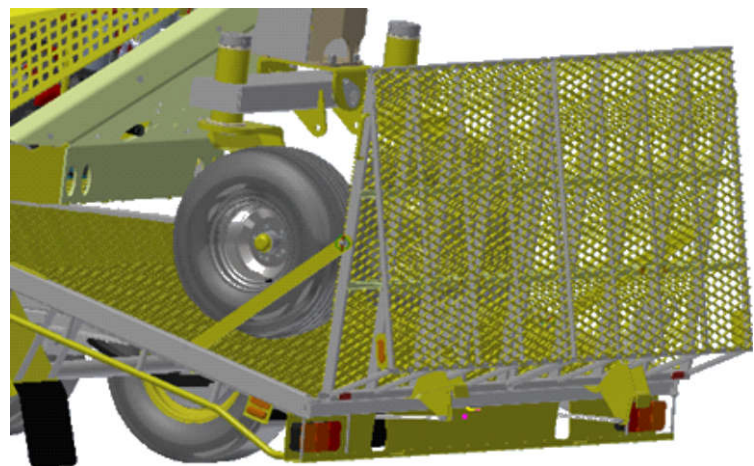

*Ramps held up with 2 x side braces clipped on.
Four gas struts make this easy to swing up*

Manufacturers and designers of horticultural equipment

Toll free : 1300 761 922

Phone: (08) 9731 1502

www.crendon.com.au



Available Through Your Local Dealer

Squirrel Beaver Tail / Flat Top Trailer

Progress to Date 2-6-2020



Tray ready for welding



*Drawbars ready for welding,
Medium on top Short on bottom*



Head frame ready for welding,



Leaf springs



Ramps no mesh on yet